

A

M

P

E

X

# MX-10/MX-35

MIXER ASSEMBLY



## WARRANTY

Ampex warrants this equipment to be free from defects in workmanship and material under normal and proper use and service, and agrees to repair or replace, without charge, all parts thereof showing such defects which are returned transportation prepaid for inspection to the Dealer from whom the equipment was purchased, within a period of 90 days from the date of delivery, provided that such inspection discloses that the defects are as above specified, and provided also, that the equipment has not been altered or repaired other than by factory approved procedures, subjected to misuse, negligence, or accident, or damaged by excessive current or otherwise, or had its serial number or any part thereof altered, defaced, or removed. Vacuum tubes and magnetic tapes carry their respective manufacturer's warranty and shall be and are hereby excluded from the provisions of this warranty, and as to these items, no warranty, express or implied, is made by Ampex. Electric motors are warranted for a period of one year. Ampex and its dealers reserve the right to inspect and repair on the customer's premises in the determination of a defect. Replacement parts supplied under this warranty carry only the unexpired portion of the original warranty.

If the purchaser shall use or allow to be used in the product any parts not supplied by Ampex through its Dealers (except those parts excluded from this warranty) then this warranty becomes void.

This Warranty is expressly in lieu of all other warranties expressed or implied and all other obligations or liabilities on the part of Ampex and no person, including any dealer, agent, or representative of Ampex, is authorized to assume for Ampex any liability on its behalf, or in its name, except to refer purchasers to this Warranty. In no event shall Ampex be liable for claims, demands or damages of any nature, however denominated; Ampex's sole warranty liability shall be to repair defective items at its factory or to supply replacement parts in accordance with the terms of this Warranty.

*Important:* Be sure you or your dealer has returned the warranty card to Ampex, Redwood City, for your registration of equipment and receipt of important supplemental data.

MODEL NO.	CATALOG NO.	SERIAL NO.	DATE OF PURCHASE
MX-10	01-96900-01		
MX-35	01-96910-01		



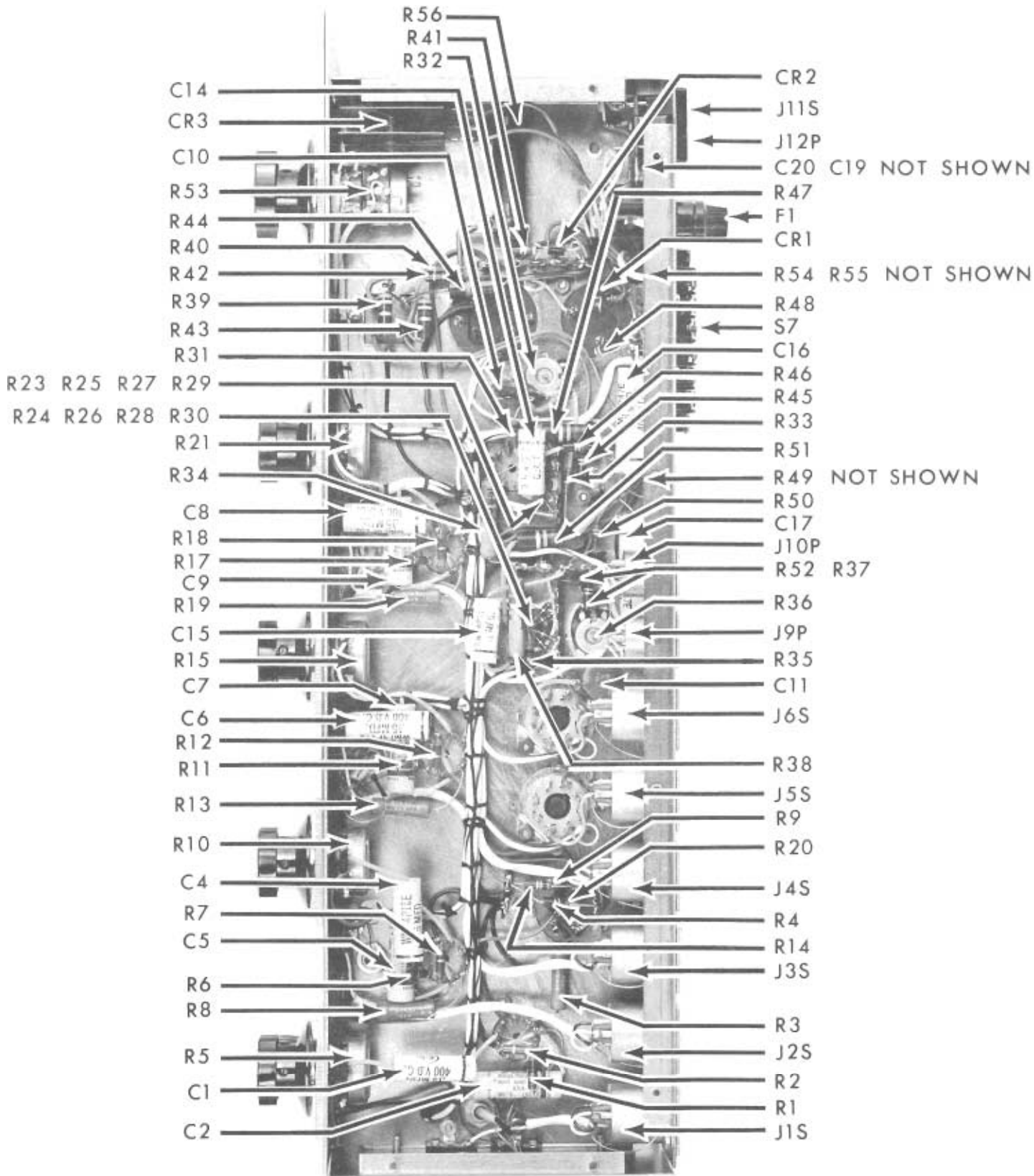

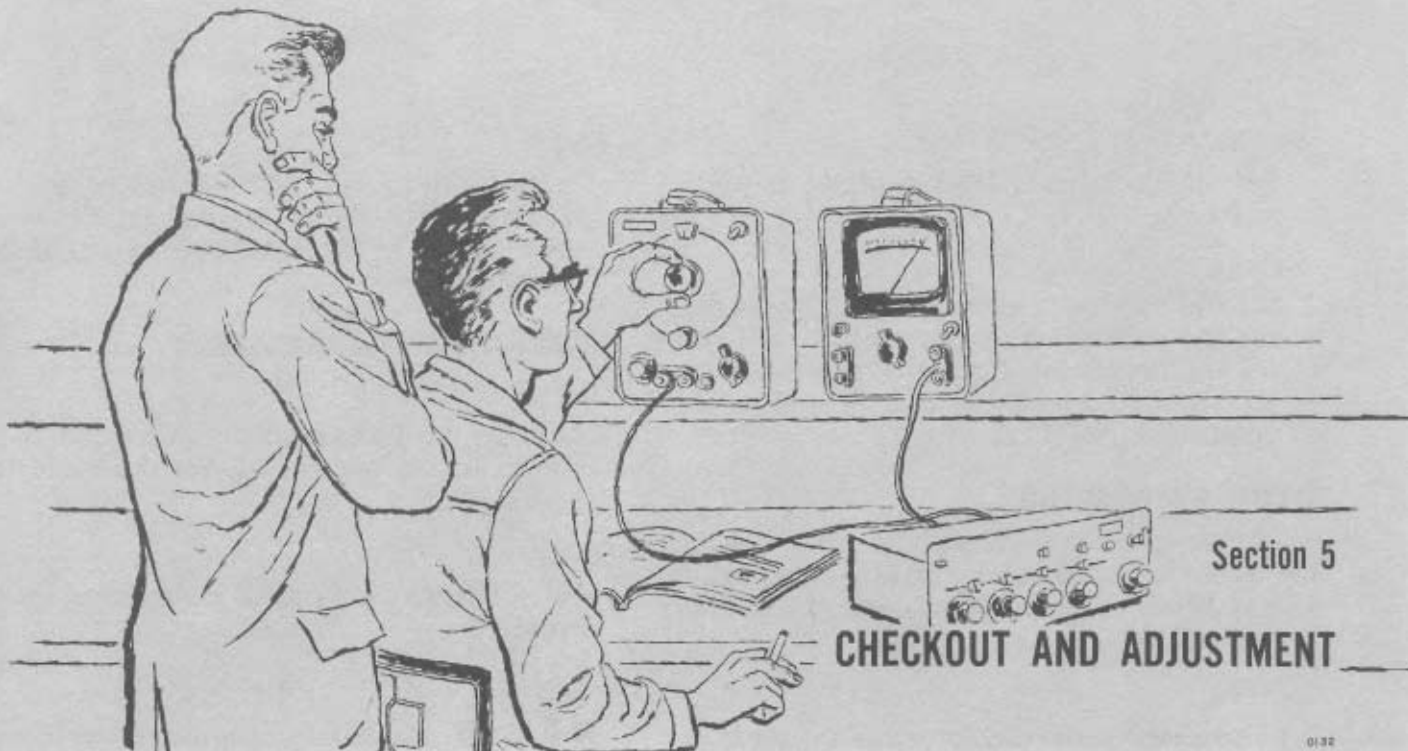

## GENERAL

In the following checkout and adjustment procedures, each input and each channel should be treated separately. That is, check microphone 1 input through channel A first, then microphone 1 input through channel B followed by microphone 2 input through channel A, etc. The sequence (which input and which channel is checked first) is unimportant.

Test equipment required for proper checkout and adjustment consists of an ac vacuum tube voltmeter capable of indicating rms voltages of 0.004 or less (Hewlett-Packard Model 400D or equivalent) and an audio oscillator with stable output from 50 cps to 15KC (Hewlett-Packard Model 200A or equivalent).

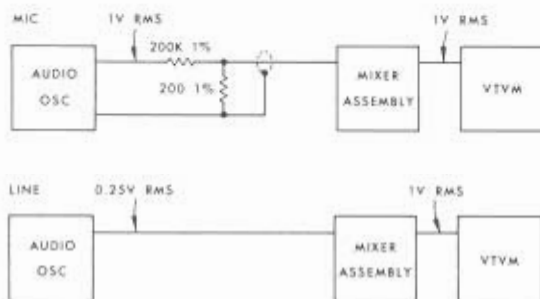

Response and gain measurement set-up

## OVERALL GAIN MEASUREMENT

With all front panel level controls set at maximum and with the LEVEL SET controls (screwdriver adjust) set at their nominal positions, a 1.0 volt output is achieved with a  $-55$  dbm microphone input or with a  $-10$  db line input. Because the db scale of the Hewlett-Packard Model 400D is calibrated with respect to a reference level of one milliwatt into 600 ohms and the nominal characteristic input impedance of the microphone preamplifiers is 200 ohms (a difference of 5 db), the gain from the microphone input *appears* to be 60 db using the test set-up illustrated.

## NOTE

*There is an adjustment of  $\pm 10$  db from this nominal gain and if a different setting of the LEVEL SET controls is used, the input and/or output levels shown on the test set-up illustration will have to be modified accordingly.*

### Step 1:

Connect the audio oscillator and the vtm as shown in the test set-up. Set the oscillator at 500 cps.

*Step 2:*

Set all front panel level controls at maximum.

*Step 3:*

Set the oscillator output level at 1 volt rms for the microphone input or 0.25 volt rms for the line input. Output of the mixer assembly should be 1 volt rms as read on the vtvm. (See NOTE above.)

### **OVERALL GAIN ADJUSTMENT**

To set the overall gain of the mixer assembly to the nominal value (or any other value within 10 db of the nominal), use the following procedure.

*Step 1:*

Connect the audio oscillator and the vtvm as shown in the test set-up. Set the oscillator at 500 cps.

*Step 2:*

Set all front panel level controls at maximum.

*Step 3:*

Set the oscillator output level at 1 volt rms for the microphone input or 0.25 volt rms for the line input. (See NOTE in the GAIN MEASUREMENT paragraph.)

*Step 4:*

Adjust the LEVEL SET control to produce a 1 volt rms output as read on the vtvm. (See NOTE in the GAIN MEASUREMENT paragraph.)

### **FREQUENCY RESPONSE MEASUREMENT**

*Step 1:*

Connect the audio oscillator and the vtvm as shown in the test set-up. Set the oscillator at 500 cps.

*Step 2:*

Set all front panel level controls at maximum.

*Step 3:*

Set the oscillator output level at 1 volt rms for the microphone input or 0.25 volt rms for the line input (or to the value used in setting the gain in the GAIN ADJUSTMENT paragraph).

*Step 4:*

Make a frequency response check by using at least ten discrete frequencies between 30 and 15,000 cps. The output level of the mixer assembly should not vary more than plus or minus one db from the normal output.



## GENERAL

The Ampex MX-10 and MX-35 Mixer Assemblies provide complete mixing facilities. Six inputs and two outputs are provided. The inputs consist of four microphone inputs and two line inputs. Switching allows any combination of up to four inputs to be connected to either or both outputs. Provisions are also made for coupling up to four mixer assemblies together.

The mixer assembly consists of a single chassis on which is mounted four separate and completely independent microphone preamplifiers and two separate output amplifiers.

## PERFORMANCE CHARACTERISTICS

### *Inputs:*

Four low level microphone inputs and two high level line inputs, any combination of four being available at any one time; incorporating high level mixing.

### *Input Impedance:*

Microphone: 200 ohm non-terminating; Line: 100K ohms unbalanced bridging (20K ohm balanced bridging with optional plug-in transformer).

### *Outputs:*

Two 1 volt normal output level; 30 volts maximum output level when fed to a bridging input with an input impedance of at least 100K ohms. Cable capacity should not exceed 0.001 microfarad to preserve high frequency response.

## PERFORMANCE CHARACTERISTICS (CONTD.)

<i>Gain:</i>	Sufficient to produce a 1 volt output with an input signal of -65 dbm on any microphone channel and -20 dbm on any line channel for maximum control settings.
<i>Frequency Response:</i>	$\pm$ 1db 40 to 15,000 cycles per second.
<i>Noise:</i>	65 db below signal for inputs of -55 dbm. This represents a noise equivalent to an input signal of -120 dbm.
<i>Distortion:</i>	Microphone Preamplifier: (distortion characteristics as a function of input level) 30 cycles— Less than 0.2% at -52 dbm input level Less than 0.4% at -42 dbm input level Less than 1.0% at -32 dbm input level 500 to 15,000 cycles— Less than 0.1% at -53 dbm input level Less than 0.3% at -43 dbm input level Less than 1.0% at -29 dbm input level Line Output: (distortion characteristics—at nominal gain—as a function of output level) 30 cycles— Less than 0.2% at 1 volt output level Less than 0.4% at 10 volt output level Less than 1.0% at 25 volt output level 500 to 15,000 cycles— Less than 0.3% at 25 volt output level
<i>Crosstalk Rejection:</i>	65 db at 500 cycles, 50 db at 10KC.
<i>Controls:</i>	Four Allen-Bradley potentiometers (calibrated step type available on special order); master gain (two gang) potentiometer; key switches for selection of microphone or line on two input positions; key switches for channel A, both or channel B on each mixer position; ac line switch; mixer coupling switch (located on the back of the chassis) two screwdriver adjust level set controls (located on the chassis).
<i>Connectors:</i>	Cannon "XL" type on all input and outputs except for a terminal strip used for mixer coupling.
<i>Power Input:</i>	105-125 volts, 50-60 cycles, 30 watts.
<i>Tubes:</i>	Six EF86/6267's and one 12AU7.
<i>Dimensions:</i>	5 - 7/32" H, 19" L, and 5 - 3/16" D (for 5 - 1/4" rack space or portable case).
<i>Accessories:</i>	Plug-in balanced bridging line input transformer (Cat. No. 58-0116-01), and plug-in balanced matching line input transformer (Cat. No. 58-0116-02).

## EQUIPMENT APPLICATIONS

The MX-10 and MX-35 Mixer Assemblies are compact, flexible speech input systems that have numerous applications in the tape recording and

sound reinforcing fields. In the tape recording field, when used with a professional quality recorder such as the Ampex PR Series, applications include: the recording of live pro-



gram material, both stereophonic and monophonic; and the dubbing of live program material over previously recorded material, both stereophonic and monophonic. In the sound reinforcing field, the mixer assembly can be used to advantage in plant paging systems and in public address or sound reinforcing installations because it permits great flexibility of switching and channel combinations. The following paragraphs and illustrations are intended to show some of the basic applications.

For the stereo recording of a live program, one basic set-up is to connect four microphones to the mixer and, using the channel selector switches, feed the "left" microphone to Ch. A, the "center" and "solo" microphones to both channels, and the "right" microphone to Ch. B.

For dubbing live stereo program material over a previously recorded stereo program, one basic set-up is to connect two microphones to microphone inputs 1 and 2 of the mixer and the outputs of a stereo tape reproducer to line inputs 1 and 2. Using the channel selector switches, feed the "left" microphone and the "left" line to Ch. A and feed the "right" microphone and the "right" line to Ch. B.

The basic set-up for monophonic recording of a live program is similar to the set-up

described for stereo, the basic difference being that all microphones are fed to Ch. A only (or to both channels when making a second simultaneous "protection" recording).

All of the above applications have considered only one mixer assembly and only one or two channel operation. Still considering one or two channel operation, two or more mixer assemblies (up to four) can be "coupled" together to provide additional inputs. Further, two or more mixer assemblies can be "stacked" together (without coupling) to provide additional channels (up to four channels can be provided with only two mixer assemblies). Finally, mixer assemblies can be both "coupled" and "stacked" in almost any combination desired. All of these applications are, of course, only basic and many variations are possible, limited only by the user's imagination and skill.

#### NOTE

*The coupling switch transfers the output of Ch. A and the output of Ch. B from the SINGLE MIXER NORMAL to the MIXER COUPLE condition simultaneously, therefore the channels of one mixer cannot be coupled to the channels of another mixer separately.*

STEREO RECORDING (LIVE)

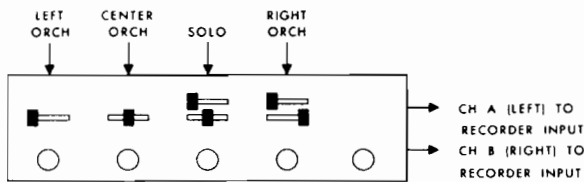

STEREO RECORDING (DUBBING)

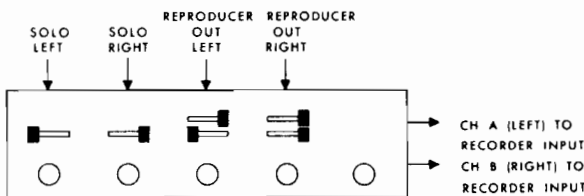

NOTES:

1. IF A SECOND "PROTECTION" RECORDING IS DESIRED, THE "CH A-BOTH-CH B" SWITCHES SHOULD BE IN THE "BOTH" POSITION.

MONOPHONIC RECORDING (LIVE)

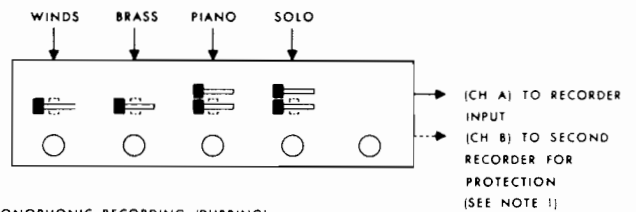

MONOPHONIC RECORDING (DUBBING)

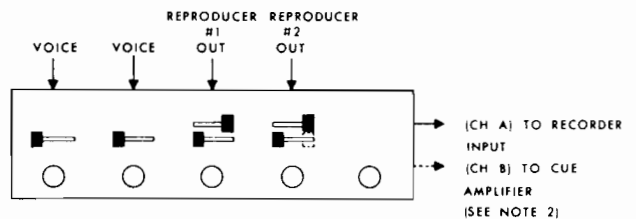

2. REPRODUCER #2 CAN BE "CUEED" WHILE RECORDING FROM OTHER INPUTS BY SWITCHING "CH A-BOTH-CH B" SWITCH TO "CH B"

0000

### Typical uses of the MX-10 mixer

# INDEX

Accessories	
Description of .....	2-2
Installation of .....	3-1
Adjustment	
Gain .....	5-2
Application	
Dubbing .....	2-3
Multichannel .....	2-3
Single-channel .....	2-3
Two-channel .....	2-3
Connections	
Multichannel .....	3-3
Multiple inputs .....	3-3
Single- and two-channel .....	3-3
Diagrams	
Interconnection .....	3-2
Measurement set-up .....	5-1
Mixer schematic .....	7-3
Output amplifier schematic .....	7-2
Parts location .....	6-9
Preamplifier schematic .....	7-2
System block .....	7-1
Troubleshooting block .....	6-1
Dimensions	
General .....	2-2
Mounting .....	3-2
Distortion specification .....	2-2
Frequency Response	
Measurement of .....	5-2
Specification .....	2-2
Gain	
Adjustment of .....	5-2
Measurement of .....	5-1
Specification .....	2-2
Instruction manual, use of .....	1-1
Measurement	
Frequency response .....	5-2
Gain .....	5-1
Noise specification .....	2-2

# INDEX

Operation	
Overall .....	4-1
Theory of .....	7-1
Ordering parts .....	6-1
Output amplifier	
Schematic diagram .....	7-2
Theory of operation .....	7-1
Parts	
List of .....	6-3
Location .....	6-9
Ordering of .....	6-1
Preamplifier	
Schematic diagram .....	7-2
Theory of operation .....	7-1
Power requirements .....	2-2
Power supply theory .....	7-2
Switching	
Description .....	2-1
Function .....	4-1
Use .....	4-2
Theory of operation	
Mixer coupling .....	7-2
Output amplifier .....	7-1
Power supply .....	7-2
Preamplifier .....	7-1



### GENERAL

The MX-10 and MX-35 Mixer Assemblies will be shipped in unmounted form only. An accessory case (Cat. No. 01-96940-01) is available in which the MX-10 may be mounted along with the PR-10 tape transport and associated electronic assembly. The MX-35 may be mounted in the Catalog No. 15-0211-00 carrying case.

All necessary hardware will be included with each mixer for mounting in a rack or in the portable case.



*MX-10 mixer assembly — ¾ view*

### INSTALLATION OF EQUIPMENT

When the mixer assembly is to be custom installed, the equipment can be mounted on a standard 19-inch relay-type rack. Mounting

dimensions for the mixer assembly are shown in the accompanying illustration.



*Rack layout (shown with PR-10 Tape Recorder)*

### INSTALLATION OF PLUG-IN ITEMS

The only plug-in items available for the mixer assemblies are the balanced bridging line input transformer (Catalog No. 58-0116-01)

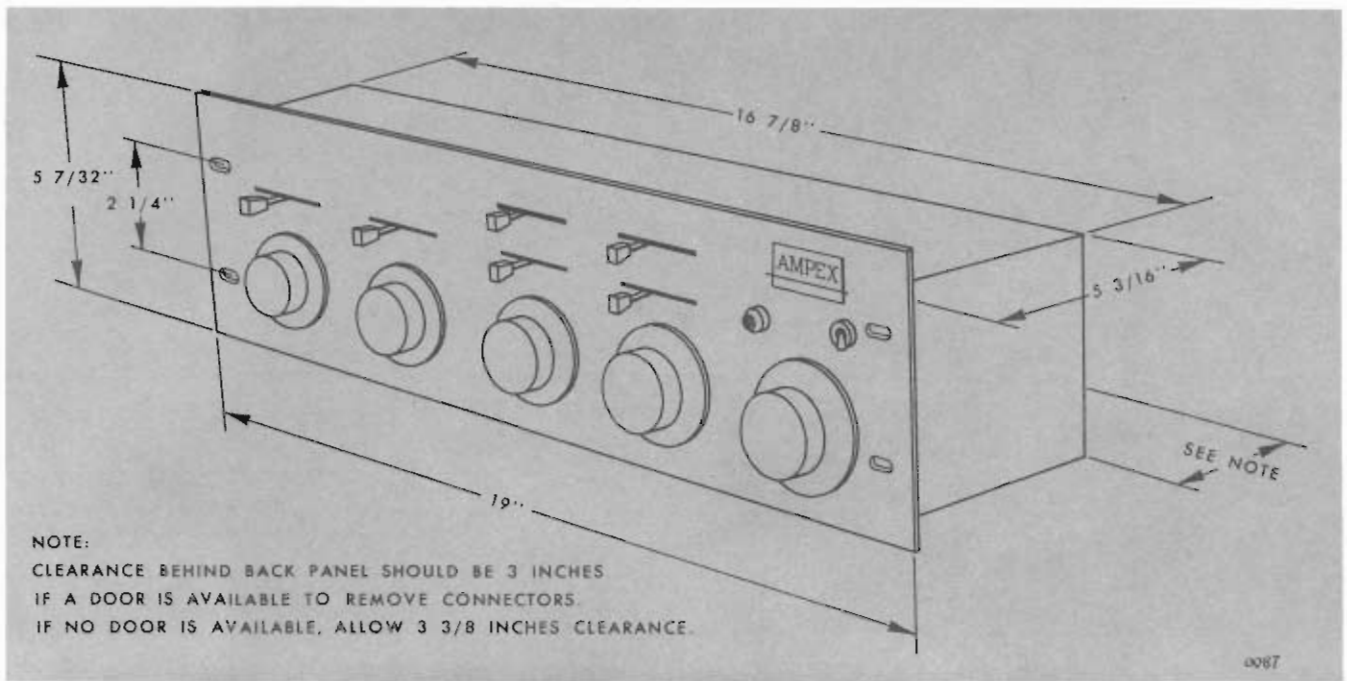

*Mounting dimensions*

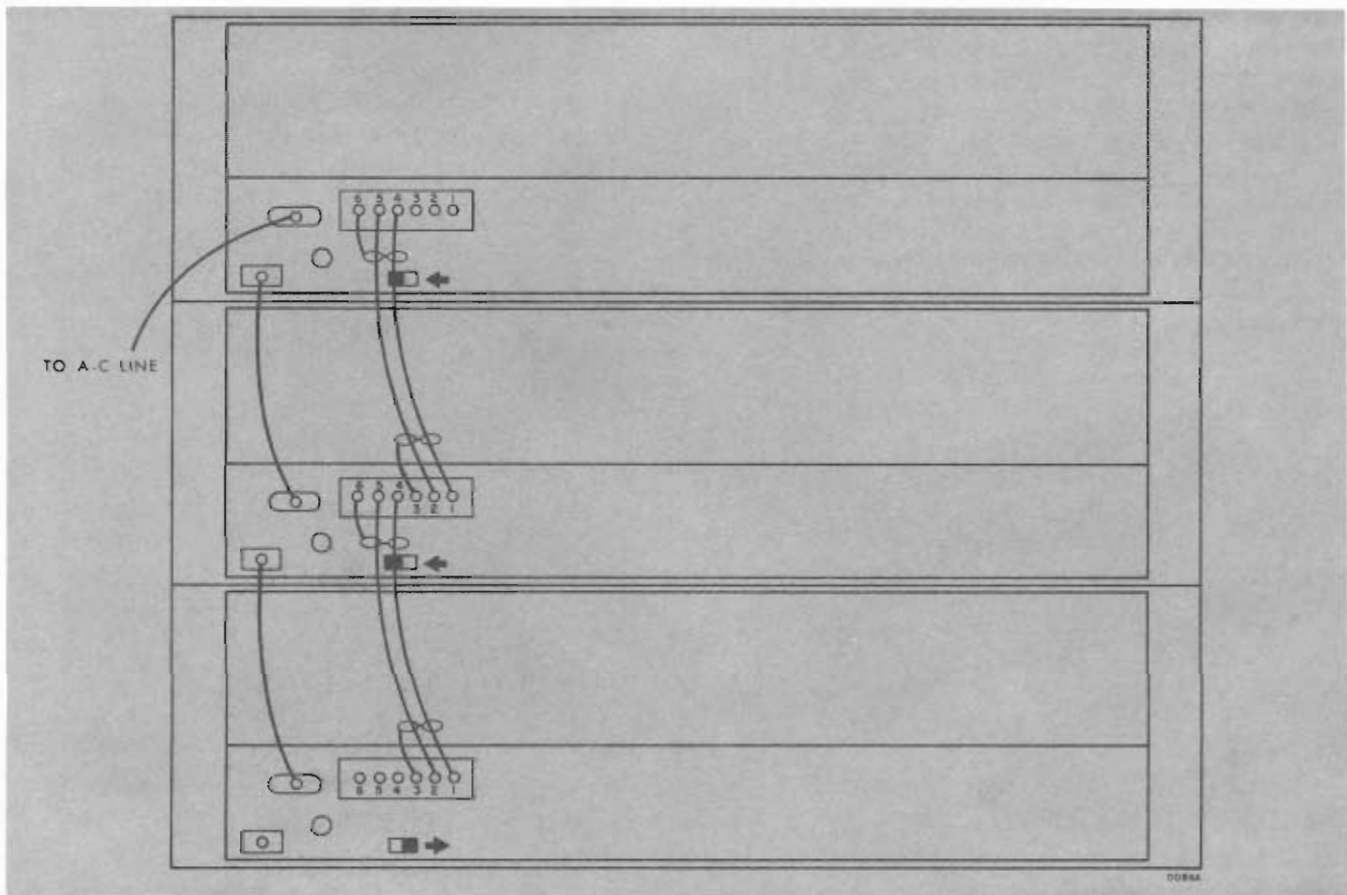

*Interconnecting two or more mixers*

and the balanced matching line input transformer (Catalog No. 58-0116-02). When either transformer is to be used, it should be plugged into socket J7S and/or J8S.

If the transformers are *not* used, the dummy plug (Catalog No. 03-0034-01), which is supplied with the equipment, *must* be plugged into socket J7S and/or J8S.

## CONNECTIONS

Connect the power cable from the a-c power input connector, J12P, on the mixer assembly to a convenient 117 volt a-c power source. Connect the *OUTput* connectors, J9P and J10P, of the mixer to the input connectors of the equipment with which the mixer assembly is to be used.

If more than four inputs are required, additional mixers must be used. In this case, the coupled mixer terminal strip TS1 (pins 4, 5 and 6) of the *first* mixer should be connected to the coupled mixer terminal strip TS1 (pins 1, 2 and 3) of the *second* mixer and the coupled mixer terminal strip TS1 (pins 4, 5 and 6) of the *second* mixer should be connected to the coupled mixer terminal strip TS1 (pins 1, 2 and 3) of the *third* mixer, etc. The *OUTput* connectors of the *last* mixer should be connected to the user's equipment. The coupled mixer switch, S7, on the rear of each of the mixers, *except the last one*, should be

in the MIXER COUPLE position. The coupled mixer switch on the last mixer should be in the SINGLE MIXER NORMAL position. When two or more mixers are coupled together in this manner, there are still *only two outputs*. The "master gain" control on the *last* mixer assembly controls overall gain while all other "master gain" controls become inoperative.

If more than two outputs are required (i.e., 3 channel operation), additional mixers are also required. In this case, however, the mixers are *not* coupled together as previously described, but rather, each mixer is connected as described for single mixer operation.

Connect the inputs (lines and/or microphones) to the mixer(s) as desired.

## NOTE

*The MX-10 Mixer Assembly is specifically designed for use with the Ampex PR Series Tape Recorder/Reproducer and the MX-35 Mixer Assembly is specifically designed for use with the Ampex 351/354 Recorder/Reproducers. Use of the mixers are, however, not limited to these recorders. The mixers may be used with any electronics equipment that has an input impedance of at least 100,000 ohms and requires 1 volt rms input or less for proper operation. Cable capacity should not exceed 1000 uuf to preserve high frequency response.*



## Section 6

# MAINTENANCE AND TROUBLESHOOTING

0137

### GENERAL MAINTENANCE INFORMATION

Careful periodic performance checks will ensure excellent equipment operation. When the system is set up according to the instructions in this manual, equipment performance should meet the high Ampex standards.

### CORRECTIVE MAINTENANCE

The first step in any corrective maintenance procedure is localizing the faulty circuit. A run through of the alignment and performance checks of the mixer assembly will help isolate the trouble and the faulty component then should be easily identifiable. A circuit for trouble shooting the mixer after the performance checks have been made (especially useful if the trouble has not been isolated) is shown below (see also—PARTS LOCATION-MIXER ASSEMBLY, and SCHEMATIC DIAGRAM-MIXER ASSEMBLY).

Disconnect any input or output when using this circuit. Using a vtvm probe and working

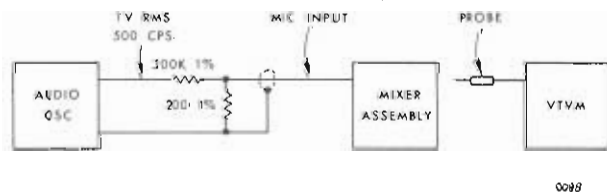

*Troubleshooting the mixer*

back from the output toward the input, check at the grid and plate of each stage until a signal is indicated on the vtvm. The trouble then is probably in the stage immediately following that point. When the faulty stage is located, the individual components can be isolated by a check of resistance and voltages. Typical voltage readings are shown on the foldout schematic diagram; voltages measured will vary with line voltage, the voltages indicated on the schematic diagram were measured with a 117 volt line voltage.

### ORDERING PARTS

The purpose of the parts list is to aid the user of AMPEX equipment in obtaining replacement parts. AMPEX franchised dealers can offer the most convenient service in providing normally replaceable parts when proper information is furnished. Parts are listed according to the schematic reference symbol, a description of the part and the AMPEX number.

On occasion, AMPEX offers certain replacement parts that are not necessarily exact replicas of those used on the original version of the equipment; but these parts are directly interchangeable with the original parts or data is provided to enable the use of the new part. The description column names the part, its composition, electrical value and manufactur-

er's number (or military specification when available)—and the AMPEX PART NUMBER.

Ampex part numbers are the exact designation for all parts used in Ampex equipment. For example: CAPACITOR, fixed; ceramic,  $0.02\mu\text{f} +80\% -20\%$ , 500 vdcw; Sprague Part No. 36C205 will always bear the Ampex Catalog Number 54-0265. THIS IS THE NUMBER

THAT SHOULD BE USED WHEN ORDERING REPLACEMENT PARTS. The schematic reference number should NOT be used for ordering parts as the part value may vary with different equipment types. Include the following information when ordering parts: Equipment Type, Equipment Serial Number, Ampex Part Number, and Description of Part. Example: 4 ea. 54-0265 capacitors for Model MX-10 (or MX-35) Mixer Assembly.



REF. NO.	PART DESCRIPTION	AMPEX PART NO.
	MIXER ASSEMBLY, MX-10: Catalog No. 01-96900-01	
	MIXER ASSEMBLY, MX-35: Catalog No. 01-96910-01	
C1	CAPACITOR, Fixed: mylar; 0.33 mfd; $\pm 10\%$ ; 400 vdcw; Goodall Type 623	035-957
C2	CAPACITOR, Fixed: electrolytic; 50 mfd; $-10\%$ +250%; 6 vdcw; Sprague Part No. TVA1100	031-123
C3	CAPACITOR, Fixed: electrolytic; 10-10-10-10 mfd; $-10\%$ +50%; 450 vdcw; Mallory Part No. FP-434	031-077
C4	(Same as C1)	035-957
C5	(Same as C2)	031-123
C6	(Same as C1)	035-957
C7	(Same as C2)	031-123
C8	(Same as C1)	035-957
C9	(Same as C2)	031-123
C10	CAPACITOR, Fixed: ceramic; 0.05 mfd; $-20\%$ +100%; 30 vdcw; Centralab Part No. DA-503	030-126
C11	(Same as C10)	030-126
C12	CAPACITOR, Fixed: electrolytic; 20-20-20-20 mfd; 450 vdcw; Sprague Type DFP	031-074
C13	CAPACITOR, Fixed: electrolytic; 40 mfd; $\pm 10\%$ ; 250 vdcw; Sprague Part No. TVL1519	031-161
C14	CAPACITOR, Fixed: mylar; 0.1 mfd; $\pm 10\%$ ; 400 vdcw; Cornell Dubilier Part No. WMF4P1E	035-999
C15	(Same as C14)	035-999
C16	CAPACITOR, Fixed: mylar; 0.47 mfd; $\pm 20\%$ ; 400 vdcw; Cornell Dubilier Part No. WMF4P47E	035-981
C17	(Same as C16)	035-981
C18	CAPACITOR, Fixed: electrolytic; 2000 mfd; $-10\%$ +250%; 15 vdcw; Mallory Part No. WP-041	031-085
C19	CAPACITOR, Fixed: paper; 0.0047 mfd; $\pm 20\%$ ; 600 vdcw; Sprague Part No. 73P47206	035-028
C20	(Same as C19)	035-028
C21	CAPACITOR, Fixed: ceramic; 4.7 pfd; $\pm 10\%$ ; 500 vdcw; Erie Type 831	54-0289
C22	(Same as C21)	54-0289
C23	CAPACITOR, Fixed: electrolytic; 40 mfd; 250 vdcw; Cornell Dubilier Type BR	031-996
CR1	DIODE, Crystal: diffused silicon; 600 PIV; Type 1N2864	57-0012
CR2	(Same as CR1)	57-0012
CR3	RECTIFIER, Selenium: Radio Receptor Part No. C11S1C1E1G	582-998
DS1	LAMP, Neon: miniature; amber; Eldema Part No. 1B9-5277	060-996
F1	FUSE, Cartridge: 0.75 amps; slow-blow; 125 v; 1/4 in. dia. by 1-1/4 in. lg.: Littlefuse Part No. 313.750	070-048
J1S	CONNECTOR, Receptacle: female; 3 contact; Cannon Part No. XLR-3-31	146-998
J2S	(Same as J1S)	146-998
J3S	(Same as J1S)	146-998
J4S	(Same as J1S)	146-998
J5S	(Same as J1S)	146-998
J6S	(Same as J1S)	146-998
J7S	SOCKET, Octal: mica; Cinch-Jones Part No. 12272-8-AM	150-010
J8S	(Same as J7S)	150-010
J9P	CONNECTOR, Receptacle: male; 3 contact; Cannon Part No. XLR-3-32	147-999
J10P	(Same as J9P)	147-999
J11S	CONNECTOR, Receptacle: female; 2 contact; Circle F Part No. M-438	146-999
J12P	CONNECTOR, Receptacle: male; 2 contact; Tower Part No. C10G10A	147-032

REF. NO.	PART DESCRIPTION	AMPEX PART NO.
R1	RESISTOR, Fixed: composition; 22K ohms; $\pm 10\%$ ; 1/2 watt; MIL-R-11A: RC20GF223K	041-064
R2	RESISTOR, Fixed: composition; 1.5K ohms; $\pm 10\%$ ; 1/2 watt; MIL-R-11A: RC20GF152K	041-050
R3	RESISTOR, Fixed: film; 47K ohms; $\pm 1\%$ ; 1 watt; Dalohm Type DC-1	042-049
R4	RESISTOR, Fixed: composition; 10K ohms; $\pm 10\%$ ; 1/2 watt; MIL-R-11A: RC20GF103K	041-060
R5	RESISTOR, Variable: composition; 100K ohms; $\pm 10\%$ ; 2 watt; Allen Bradley Part No. JA1N056S104AZ	044-015
R6	(Same as R1)	041-064
R7	(Same as R2)	041-050
R8	(Same as R3)	042-049
R9	(Same as R4)	041-060
R10	(Same as R5)	044-015
R11	(Same as R1)	041-064
R12	(Same as R2)	041-050
R13	(Same as R3)	042-049
R14	(Same as R4)	041-060
R15	(Same as R5)	044-015
R16	RESISTOR, Fixed: composition; 1.2 megohms; $\pm 10\%$ ; 1/2 watt; MIL-R-11A: RC20GF125K	041-084
R17	(Same as R1)	041-064
R18	(Same as R2)	041-050
R19	(Same as R3)	042-049
R20	(Same as R4)	041-060
R21	(Same as R5)	044-015
R22	(Same as R16)	041-084
R23	RESISTOR, Fixed: composition; 330K ohms; $\pm 5\%$ ; 1/4 watt; Allen Bradley Type CB	041-932
R24	(Same as R23)	041-932
R25	(Same as R23)	041-932
R26	(Same as R23)	041-932
R27	(Same as R23)	041-932
R28	(Same as R23)	041-932
R29	(Same as R23)	041-932
R30	(Same as R23)	041-932
R31	RESISTOR, Fixed: composition; 220K ohms; $\pm 10\%$ ; 1/2 watt; MIL-R-11A: RC20GF224K	041-076
R32	RESISTOR, Variable: composition; 1 megohm; $\pm 20\%$ ; 3 watt; Chicago Telephone Type PE-200	044-993
R33	RESISTOR, Fixed: composition; 8.2K ohms; $\pm 10\%$ ; 1/2 watt; MIL-R-11A: RC20GF822K	041-059
R34	RESISTOR, Fixed: wirewound; 1.5K ohms; $\pm 5\%$ ; 1 watt; IRC Type BW-1	043-989
R35	(Same as R31)	041-076
R36	(Same as R32)	044-993
R37	(Same as R33)	041-059
R38	(Same as R34)	043-989
R39	RESISTOR, Fixed: composition; 3.9K ohms; $\pm 10\%$ ; 1 watt; MIL-R-11A: RC32GF392K	041-153
R40	RESISTOR, Fixed: composition; 4.7K ohms; $\pm 10\%$ ; 1/2 watt; MIL-R-11A: RC20GF472K	041-056
R41	RESISTOR, Fixed: composition; 100K ohms; $\pm 10\%$ ; 1/2 watt; MIL-R-11A: RC20GF104K	041-072
R42	(Same as R40)	041-056
R43	(Same as R39)	041-153
R44	RESISTOR, Fixed: composition; 2.2K ohms; $\pm 10\%$ ; 2 watt; MIL-R-11A: RC42GF222K	041-205
R45	RESISTOR, Fixed: composition; 240K ohms; $\pm 5\%$ ; 1/2 watt; MIL-R-11A: RC20GF244J	041-374
R46	RESISTOR, Fixed: composition; 560K ohms; $\pm 10\%$ ; 1/2 watt; MIL-R-11A: RC20GF564K	041-081

REF. NO.	PART DESCRIPTION	AMPEX PART NO.
R47	RESISTOR, Fixed: composition; 22K ohms; $\pm 10\%$ ; 2 watt; MIL-R-11A: RC42GF223K	041-216
R48	RESISTOR, Fixed: composition; 150K ohms; $\pm 10\%$ ; 1/2 watt; MIL-R-11A: RC20GF154K	041-074
R49	(Same as R45)	041-374
R50	(Same as R46)	041-081
R51	(Same as R47)	041-216
R52	(Same as R48)	041-074
R53	POTENTIOMETER, Dual: ganged; 25K ohms	96928-01
R54	RESISTOR, Fixed: composition; 24K ohms; $\pm 5\%$ ; 1/2 watt; MIL-R-11A: RC20GF243J	041-369
R55	(Same as R54)	041-369
R56	RESISTOR, Fixed: wirewound; 2 ohms; $\pm 10\%$ ; 5 watt; Tru-Ohm Type X-60	043-990
R57	RESISTOR, Fixed: composition; 2.2K ohms; $\pm 10\%$ ; 1/2 watt; MIL-R-11A: RC20GF222K	041-052
R58	(Same as R57)	041-052
S1	SWITCH, Mixer	96925-01
S2	(Same as S1)	96925-01
S3	SWITCH, Mixer	96926-01
S4	(Same as S3)	96926-01
S5	(Same as S3)	96926-01
S6	(Same as S3)	96926-01
S7	SWITCH, Slide: DPDT	96139-02
S8	SWITCH, Toggle: SPST; paddle handle; 3 amp; Circle F Part No. 1887-L4P	120-999
T1	TRANSFORMER, Microphone	96908-01
T2	(Same as T1)	96908-01
T3	(Same as T1)	96908-01
T4	(Same as T1)	96908-01
T5	TRANSFORMER, Power	96144-01
TS1	STRIP, Terminal: barrier; 6 terminals; Cinch- Jones Part No. 6-140Y	180-111
V1	TUBE, Electron: 9 pin; miniature; Amperex Type EF86/6267	012-098
V2	(Same as V1)	012-098
V3	(Same as V1)	012-098
V4	(Same as V1)	012-098
V5	(Same as V1)	012-098
V6	(Same as V1)	012-098
V7	TUBE, Electron: 9 pin; miniature; Amperex Type 12AU7	012-107
	INDICATOR, Reset	50735-02
	PLUG ASSEMBLY, Dummy	17420-01
	KNOB, Key tab (MX-10)	96922-01
	KNOB, Key tab (MX-35)	96922-02
	CORD, Power Input	084-004
	POST, Fuse: Littelfuse Part No. 342012	085-001
	SHIELD, Tube: 9 pin; Cinch-Jones Part No. 9S2	160-012
	KNOB, Medium dark grey (MX-10)	96585-01
	KNOB, Black (MX-35)	230-003
	KNOB, Light grey (MX-10)	96585-02
	KNOB, Black (MX-35)	230-004
	SOCKET, Tube: 9 pin; Cinch-Jones Part No. 53F12621	150-020
	CONNECTOR, Plug: female; 3 contact; Cannon Part No. XL-3-11	144-003

**SCHEMATIC DIAGRAM**  
**MX-35 MIXER**  
 Catalog No. 96910-01  
 D-96905

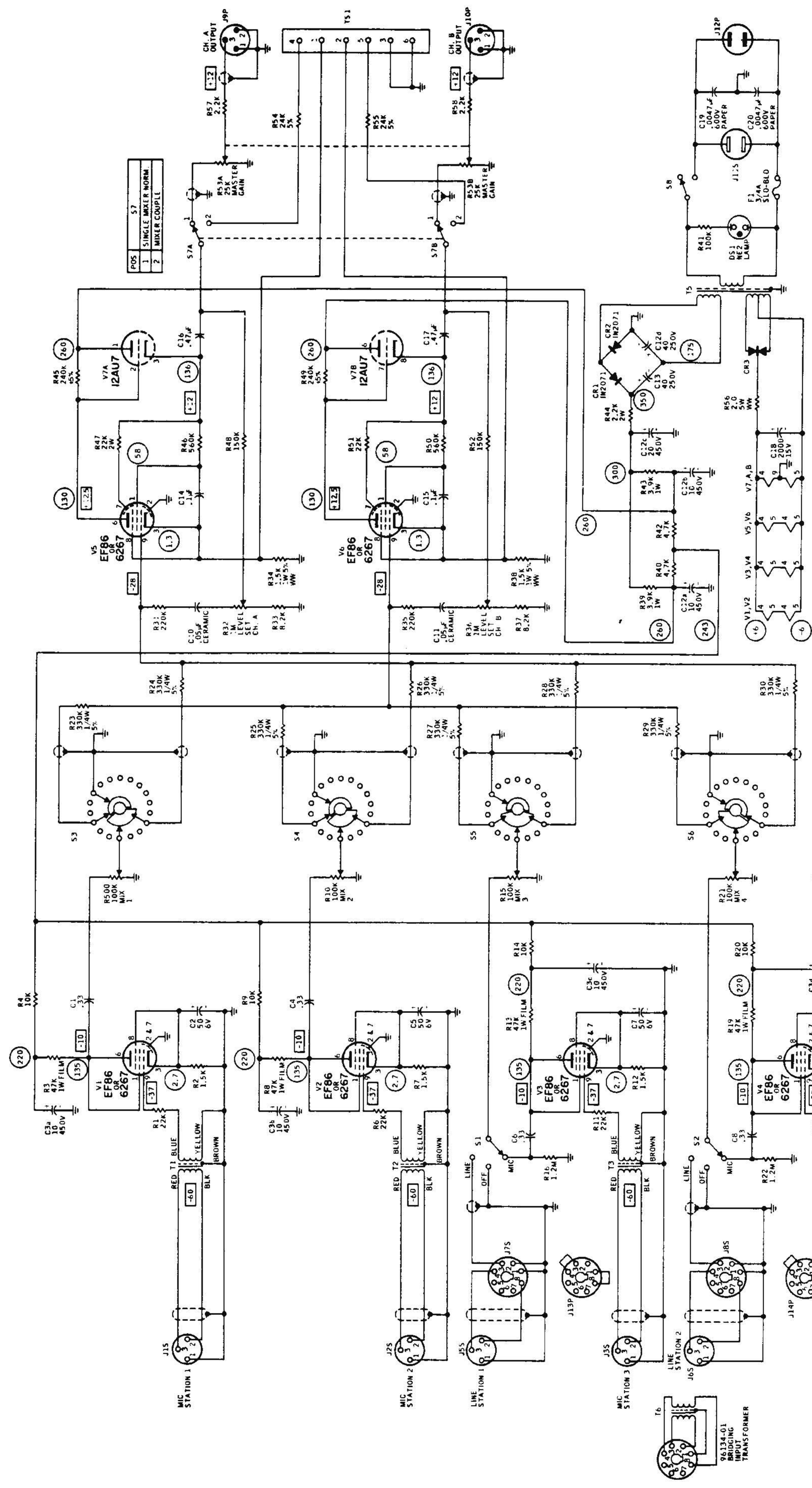

POS	57
1	SINGLE MIXER NORM
2	MIXER COUPL

- NOTES**
1. ALL CAPACITORS ARE IN MICROFARADS (μF) UNLESS OTHERWISE NOTED. ALL CAPACITORS BELOW 1.0μF ARE M/LAR FILM UNLESS OTHERWISE NOTED.
  2. ALL RESISTORS ARE IN OHMS, 0.5 WATT UNLESS OTHERWISE NOTED.
  3. SWITCHES S3, S4, S5, & S6 ARE CH. A. BOTH CH. B. S3 & S4 ARE SHOWN IN "CH. A" POSITION. S5 IS SHOWN IN THE "BOTH" POSITION, & S6 IS SHOWN IN THE "B" POSITION.
  4. SWITCHES S1, S2, S7, S8, S9, S10, S11, & S12 ARE SHOWN IN MIC POSITION AND ARE SHOWN IN LINE POSITION.

- LEGEND**
- DC VOLTAGES
  - SIGNAL VOLTAGES. SIGNAL VOLTAGES MEASURED WITH AC VTM AND EXPRESSED IN % REFERRED TO 0.78 VOLTS





Section 4

OPERATING INSTRUCTIONS

0136

**CONTROLS**

On the front panel of the mixer assembly are facilities for setting the levels of the individual inputs and the combined outputs. Switching allows each input to be fed to either or both outputs and additional switching allows the selection of either mike or line input

in the No. 3 and No. 4 mixer position. All switching regardless of combination maintains proper balance and isolation between channels.

The following table describes the function of each operating control. All controls listed are on the front panel of the mixer unless otherwise noted.

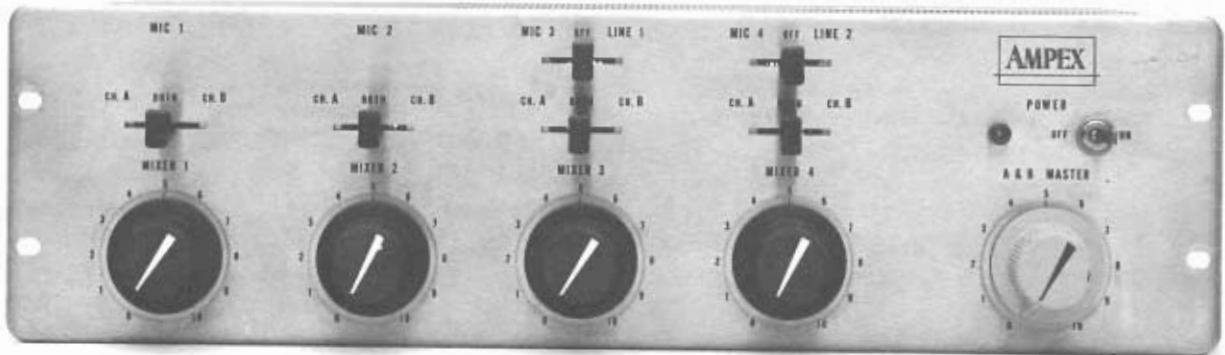

0001

*Operating controls*

<i>Item</i>	<i>Ref Sym</i>	<i>Function</i>
POWER ON-OFF SWITCH	S8	Controls power to the mixer assembly. Indicator lamp DS1 is lit when power is ON.
MICROPHONE-LINE SWITCH	S1 S2	Used to select Microphone 3 or LINE 1 (switch S1) and Microphone 4 or LINE 2 (switch S2). When in the center (OFF) position, no output is obtained from that mixer position.

CH. A - CH. B SELECTOR SWITCH	S3 S4 S5 S6	Used to feed the input to either or both of the outputs.
MIXER LEVEL	R5 R10 R15 R21	Adjusts the level of the individual inputs.
A & B MASTER LEVEL	R53	Adjusts the level of the combined inputs.
COUPLED MIXER SWITCH	S7 (rear panel)	Allows two or more mixer assemblies to be coupled together.
LEVEL SET	R32 (Chas R36 sis)	Adjusts the overall gain and balance of the mixer assembly.

### APPLYING POWER

Power is supplied through POWER switch S8 which must be turned on to operate the mixer assembly. If more than one mixer assembly is used, the POWER switch on each mixer must be turned on. The mixer assembly is fused by the  $\frac{3}{4}$  ampere fuse F1.

### SETTING UP THE CONTROLS

#### NOTE

*To avoid overloading the user's equipment, the gain controls should ALL be turned to 0 (maximum counter-clockwise rotation) before starting the following procedure.*

Set the gain controls on the associated equipment to the desired position. Set the channel selector switches and MICrophone-LINE selector switches on the mixer as desired. Set the A&B MASTER gain control on the mixer assembly to approximately 12 on the dial.

Turn the individual MIXER gain controls to provide sufficient signal strength and proper balance, taking care that the combined inputs do not overload the associated equipment.

When a high output level microphone (-30 dbm or higher) is used, it is preferable to turn down the individual MIXER gain controls rather than the A & B MASTER gain control.

Turn the associated reset dials on the mixer assembly to the corresponding position for the control concerned so that the gain controls may be turned down and then returned to the same volume (as with fading in or out).

### OPERATION OF THE EQUIPMENT

After the controls and reset dials have been set as outlined in the preceding paragraph, operation consists of varying the controls (around the gain indicated by the reset dials) in accordance with the program material. Beyond these operating instructions, operation is a matter of personal preference and proficiency.

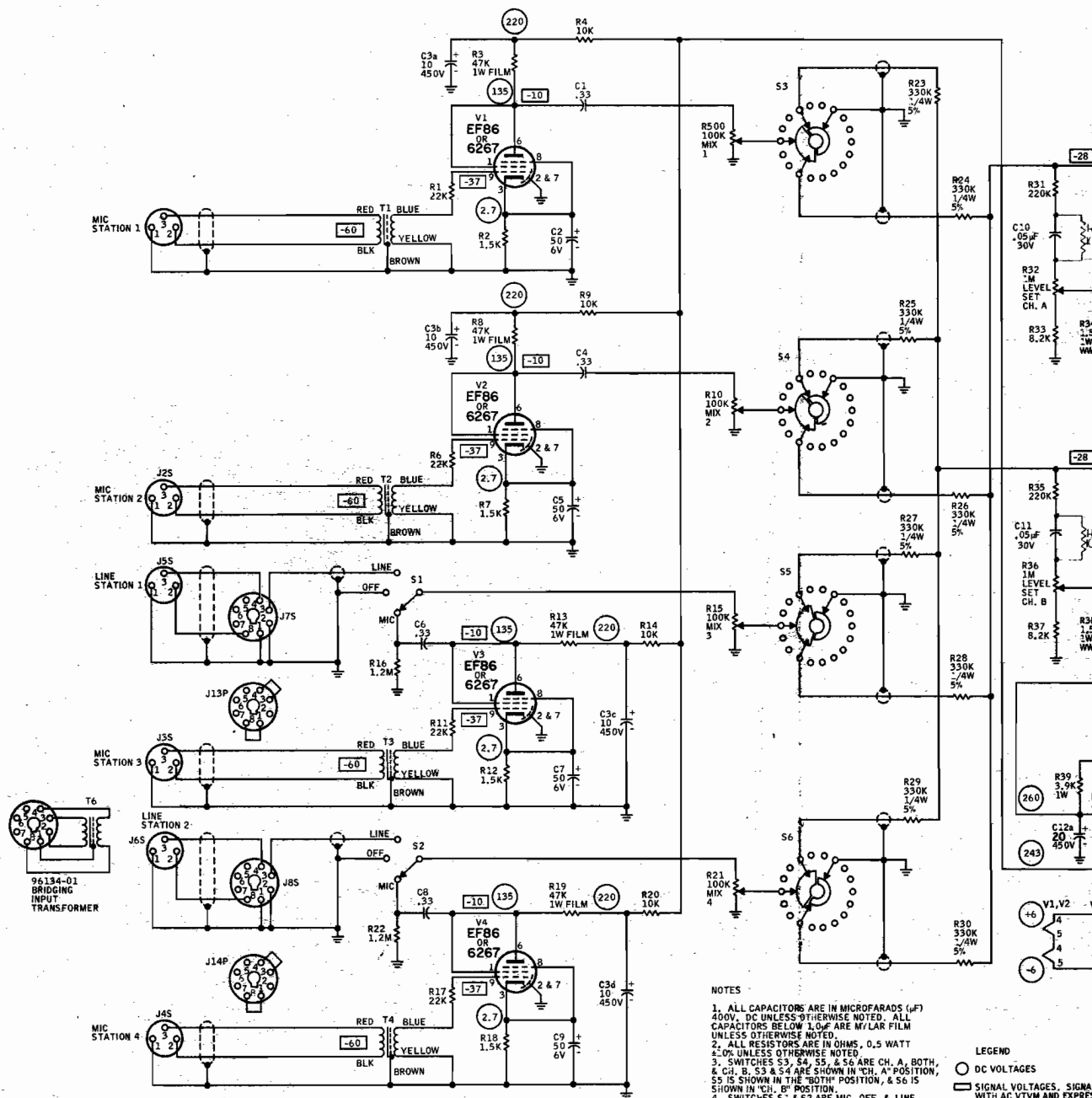

**NOTES**  
 1. ALL CAPACITORS ARE IN MICROFARADS (μF) 400V. DC UNLESS OTHERWISE NOTED. ALL CAPACITORS BELOW 1.0μF ARE MYLAR FILM UNLESS OTHERWISE NOTED.  
 2. ALL RESISTORS ARE IN OHMS, 0.5 WATT ±.0% UNLESS OTHERWISE NOTED.  
 3. SWITCHES S3, S4, S5 & S6 ARE CH. A, BOTH, & CH. B. S3 & S4 ARE SHOWN IN "CH. A" POSITION, S5 IS SHOWN IN THE "BOTH" POSITION, & S6 IS SHOWN IN "CH. B" POSITION.  
 4. SWITCHES S1 & S2 ARE MIC, OFF, & LINE, AND ARE SHOWN IN MIC POSITION.

**LEGEND**  
 ○ DC VOLTAGES  
 □ SIGNAL VOLTAGES. SIGNAL WITH AC VTVM AND EXPRES: 0.78 VOLTS.



# SCHEMATIC DIAGRAM

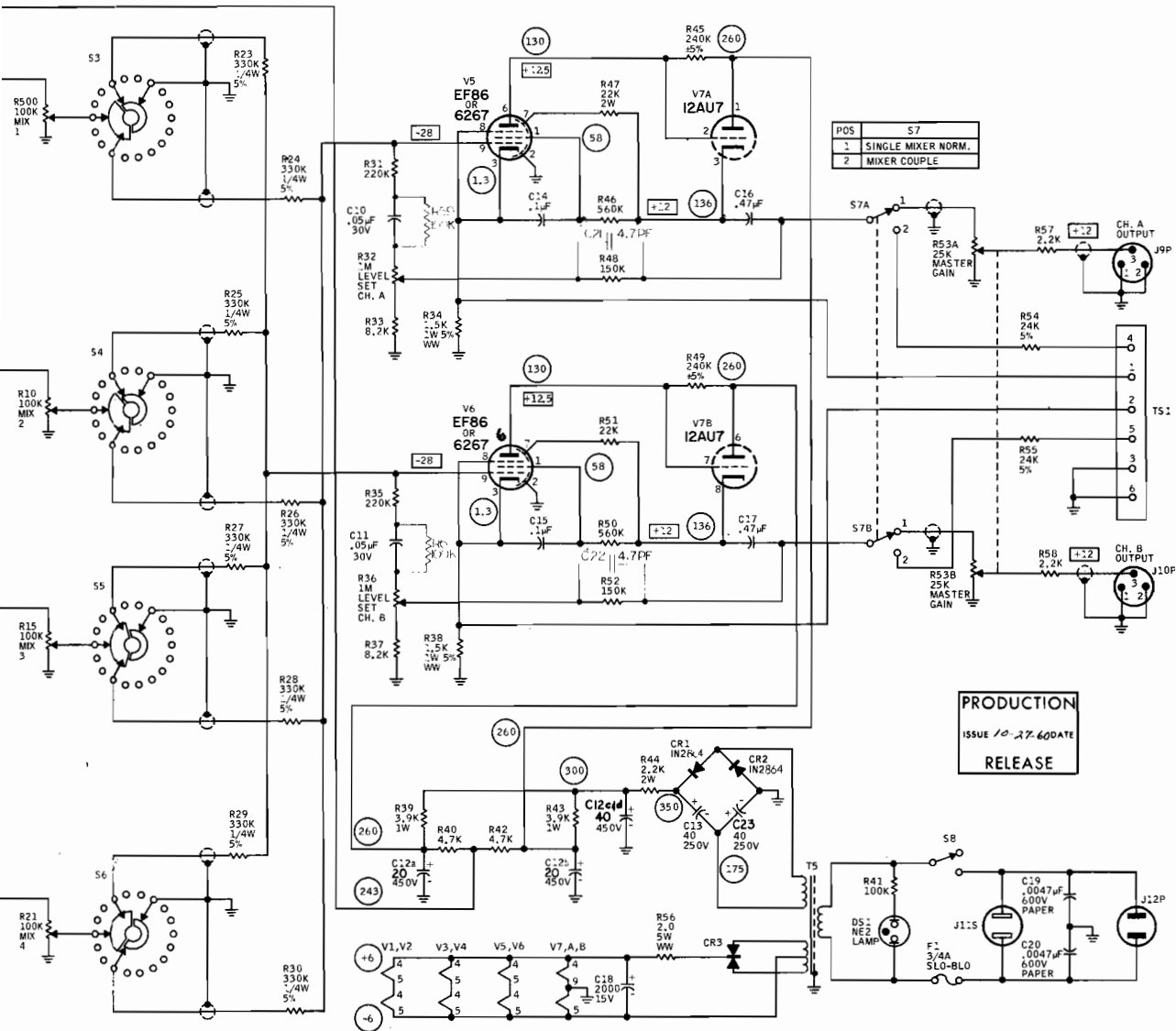

POS	S7
1	SINGLE MIXER NORM.
2	MIXER COUPLE

**PRODUCTION**  
ISSUE 10-17-60 DATE  
**RELEASE**

- NOTES**
1. ALL CAPACITORS ARE IN MICROFARADS (μF) 400V, DC UNLESS OTHERWISE NOTED. ALL CAPACITORS BELOW 1.0μF ARE MYLAR FILM UNLESS OTHERWISE NOTED.
  2. ALL RESISTORS ARE IN OHMS, 0.5 WATT ±0% UNLESS OTHERWISE NOTED
  3. SWITCHES S3, S4, S5, & S6 ARE CH. A, BOTH, & CH. B. S3 & S4 ARE SHOWN IN "CH. A" POSITION, S5 IS SHOWN IN THE "BOTH" POSITION, & S6 IS SHOWN IN "CH. B" POSITION.
  4. SWITCHES S1 & S2 ARE MIC. OFF, & LINE, AND ARE SHOWN IN MIC POSITION.

**LEGEND**

○ DC VOLTAGES  
□ SIGNAL VOLTAGES. SIGNAL VOLTAGES MEASURED WITH AC VTVM AND EXPRESSED IN :S REFERRED TO 0.78 VOLTS.

# TABLE OF CONTENTS

1	INTRODUCTION	
	Use of the Instruction Manual.....	1-1
	The General Description Section.....	1-1
	The Installation Section.....	1-1
	The Operation Section.....	1-1
	The Checkout and Adjustment Section.....	1-1
	The Maintenance and Troubleshooting Section.....	1-2
	The Theory of Operation Section.....	1-2
	The Notes and Bulletins Section.....	1-2
	The Index.....	1-2
2	DESCRIPTION	
	General.....	2-1
	Performance Characteristics.....	2-1
	Equipment Applications.....	2-2
3	INSTALLATION	
	General.....	3-1
	Installation of Equipment.....	3-1
	Installation of Plug-In Items.....	3-1
	Connections.....	3-3
4	OPERATING INSTRUCTIONS	
	Controls.....	4-1
	Applying Power.....	4-2
	Setting Up the Controls.....	4-2
	Operation of the Equipment.....	4-2
5	CHECKOUT AND ADJUSTMENT	
	General.....	5-1
	Overall Gain Measurement.....	5-1
	Overall Gain Adjustment.....	5-2
	Frequency Response Measurement.....	5-2
6	MAINTENANCE AND TROUBLESHOOTING	
	General Maintenance Information.....	6-1
	Corrective Maintenance.....	6-1
	Ordering Parts.....	6-1
	Parts List, Mixer Asembly.....	6-3
7	THEORY OF OPERATION	
	Microphone Preamplifiers.....	7-1
	Output Amplifiers.....	7-1
	Mixer Coupling.....	7-2
	Power Supply.....	7-2
8	NOTES AND BULLETINS	8-1
	INDEX	9-1

## LIST OF ILLUSTRATIONS

2	Typical Uses of the MX-10 Mixer.....	2-3
3	MX-10 Mixer Assembly — $\frac{3}{4}$ View.....	3-1
	Rack Layout (Shown with PR-10 Tape Recorder).....	3-1
	Mounting Dimensions.....	3-2
	Interconnecting Two or More Mixers.....	3-2
4	Operating Controls.....	4-1
5	Response and Gain Measurement Set-Up.....	5-1
6	Troubleshooting the Mixer.....	6-1
	Parts Location, MX-10 Mixer.....	6-9
7	Block Diagram, MX-10 Mixer.....	7-1
	Partial Schematic Diagram, Microphone Preamplifier.....	7-2
	Partial Schematic Diagram, Output Amplifier.....	7-2
	Schematic Diagram, MX-10 Mixer.....	7-3

PARTS LOCATION  
MX-10 MIXER  
Catalog No. 96900-01

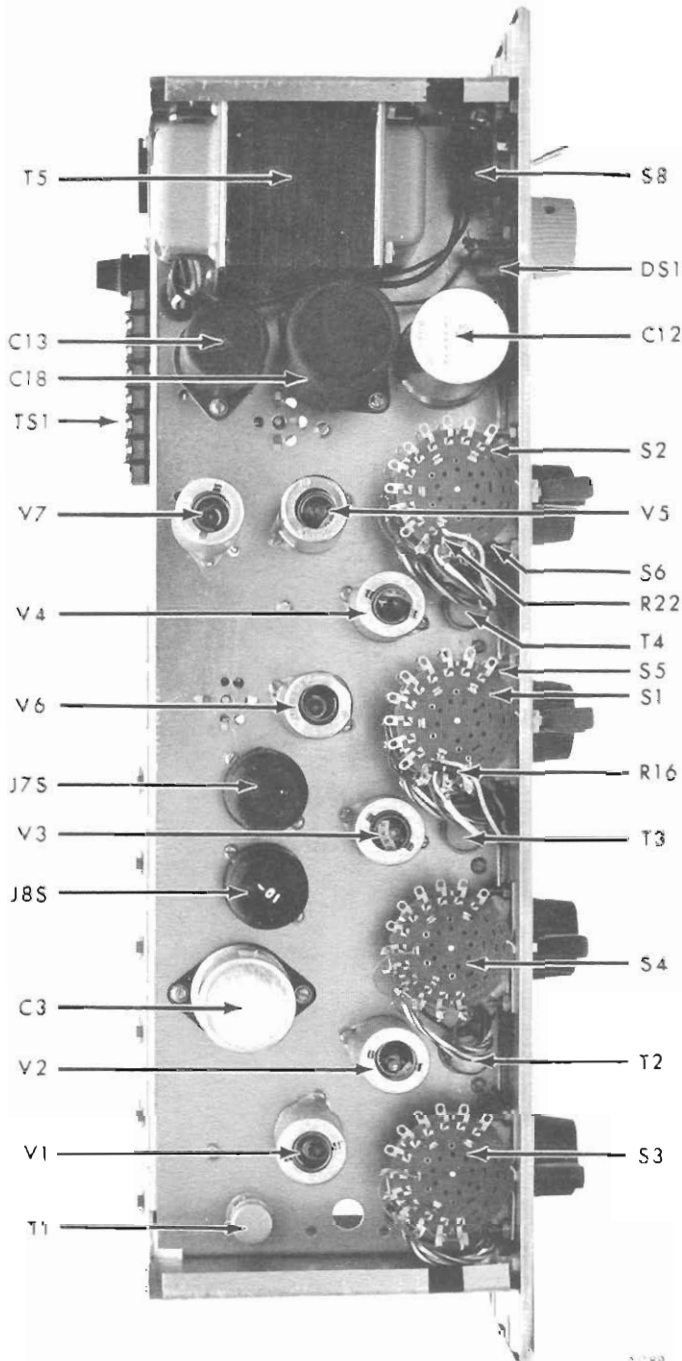

PARTS LOCATION  
MX-35 MIXER

